

CREALITY

CR20 Pro 3D Printer Guide Book

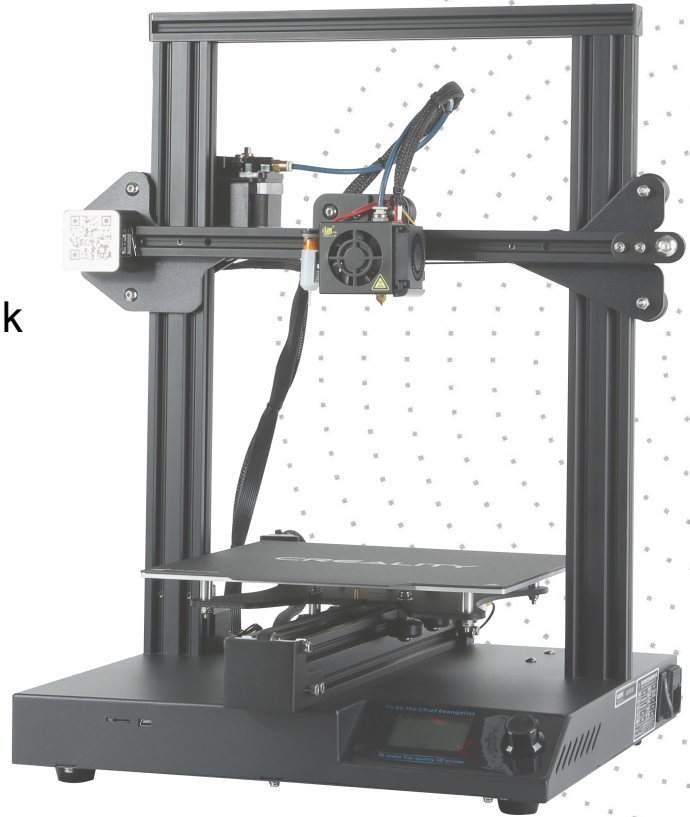

This guide book is for standard CR20 Pro.

Please plug the power cord into a three-hole power jack.

Detailed instructions for use are available on the TF card.

NOTES

1. Do not use the printer any way other than described herein in order to avoid personal injury or property damage.
2. Do not place the printer near any heat source or flammable or explosive objects. We suggest placing it in a well-ventilated, low-dust environment.
3. Do not expose the printer to violent vibration or any unstable environment, as this may cause poor print quality.
4. Before using experimental or exotic filaments, we suggest using standard filaments such as ABS or PLA to calibrate and test the machine.
5. Do not use any other power cable except the one supplied. Always use a grounded three-prong power outlet.
6. Do not touch the nozzle or printing surface during operation as they may be hot. Keep hands away from machine while in use to avoid burns or personal injury.
7. Do not wear gloves or loose clothing when operating the printer. Such cloths may become tangled in the printers moving parts leading to burns, possible bodily injury, or printer damage.
8. When cleaning debris from the printer hotend, always use the provided tools. Do not touch the nozzle directly when heated. This can cause personal injury.
9. Clean the printer frequently. Always turn the power off when cleaning, and wipe with a dry cloth to remove dust, adhered printing plastics or any other material off the frame, guide rails, or wheels . Use glass cleaner or isopropyl alcohol to clean the print surface before every print for consistent results.
10. Children under 10 years of age should not use the printer without supervision.

CONTENTS

Dear consumers,

Thank you for choosing our products. For the best experience, please read the instructions before operating the Printer. Our 3D team will always be ready to give you the best service. Please contact us via the phone number or e-mail address provided at the end when you encounter any problem with the Printer.

For a better experience in using our product, you may learn how to use the Printer in the following ways:

View the accompanied instructions and videos on the TF card.

Visit our official website at www.creality3d.cn You will find relevant software/hardware information, contact details and operation and maintenance instructions on the website.

Introduction

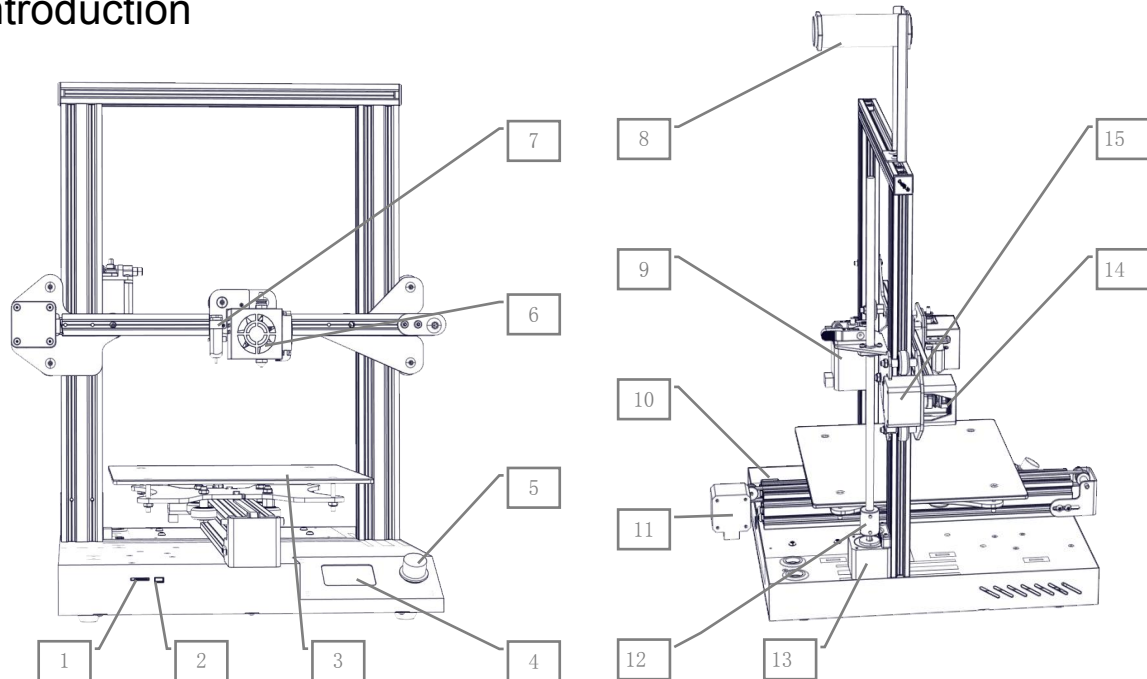

1. TF Card Slot

2. USB Port

3. Platform

4. LCD Display Screen

5. Control Knob

6. Nozzle Kit

7. Automatic leveling (Bill Touch)

8. Filament Rack

9. Extruder (E) Steppers

10. Y Axis Limit Switch

11. Y Axis Steppers

12. Coupling

13. Z Axis Steppers

14. X Axis Limit Switch

15. X Axis Steppers

General List

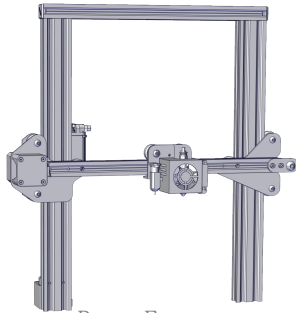

Base Frame

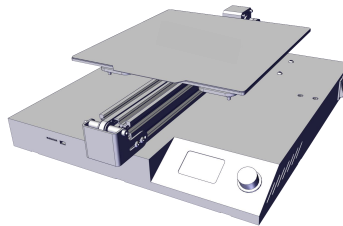

Gantry Frame



Tool Kit

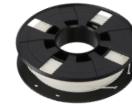

Sample Filament (200g)

◆ Tool List

No.	Image	Name	Qty
1		Scraper	1
2		Diagonal Pliers	1
3		TF Card & Card Reader	2
4		Wrench & Screw Driver	8

No.	Image	Name	Qty
5		Nozzle Cleaner	1
6		Rack Bracket	1
7		Rack Tube	1
8		Rack Tube Nuts	2

No.	Image	Name	Qty
10		Spare Parts	2
11		Power Cable	1
12		M5X25 Black Hex-Bolt & Lock Washer	4
13		M4X8 Screw & M4 T-type Screw	4

Installation

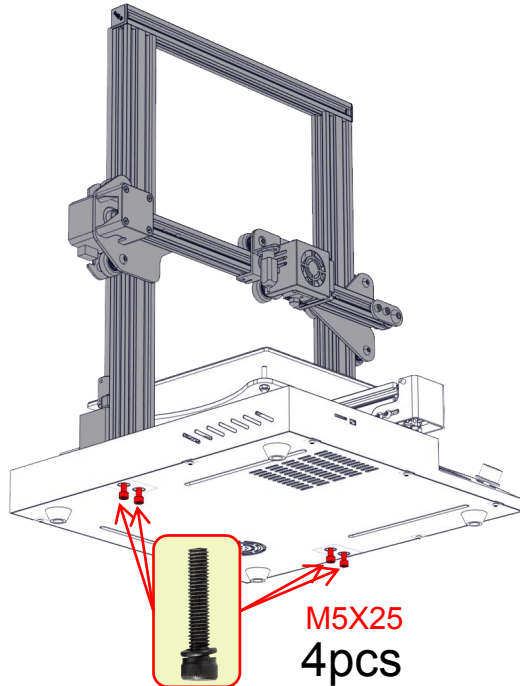
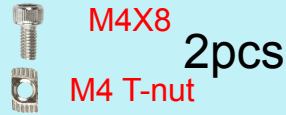
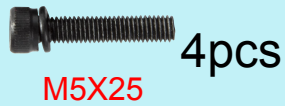

Install the Gantry Frame

Install the
Rack

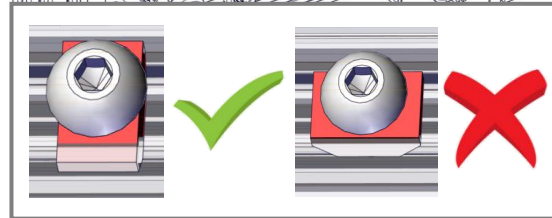
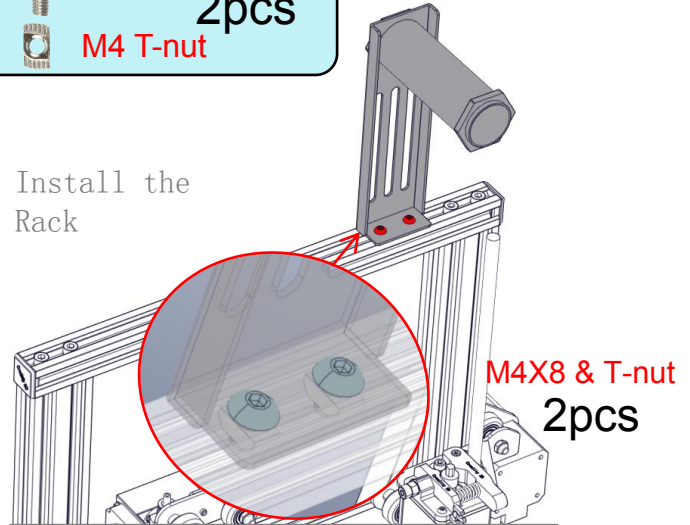

Cable Connection

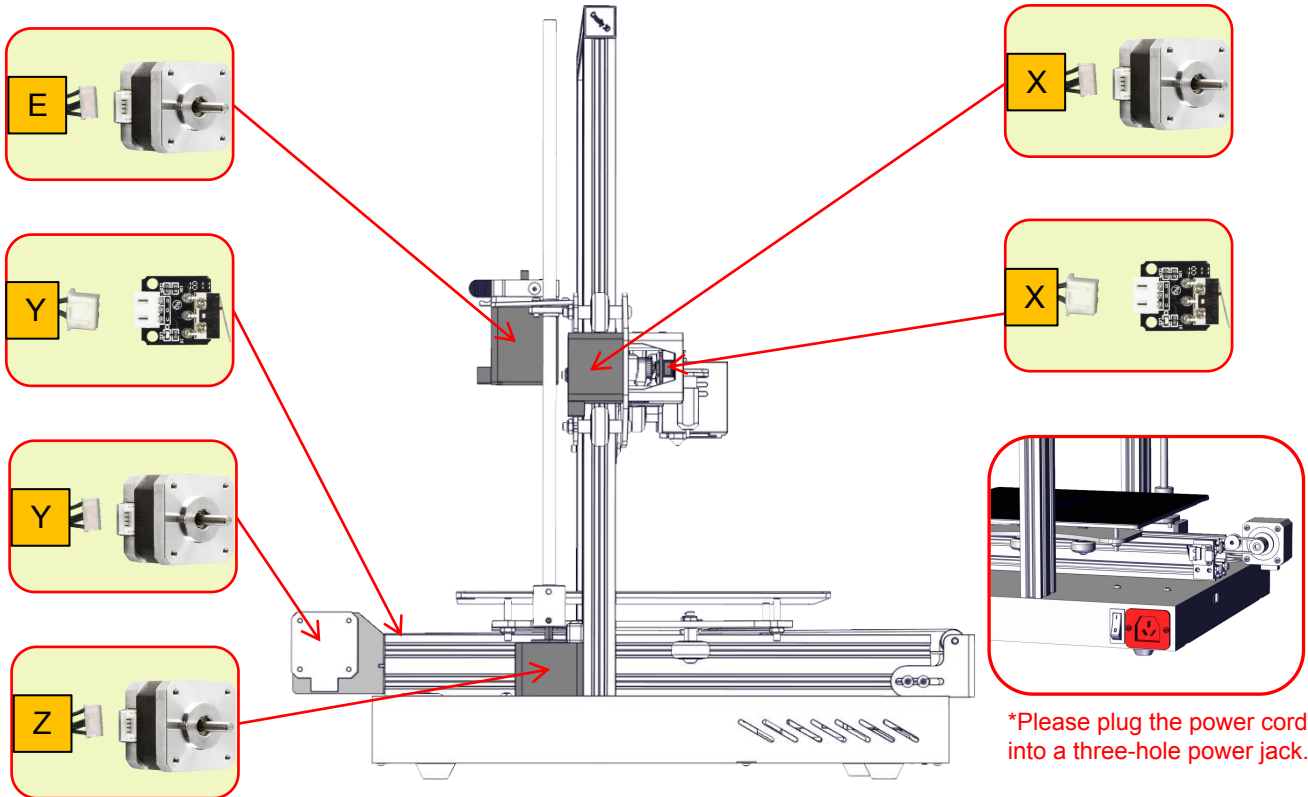

Screen Information

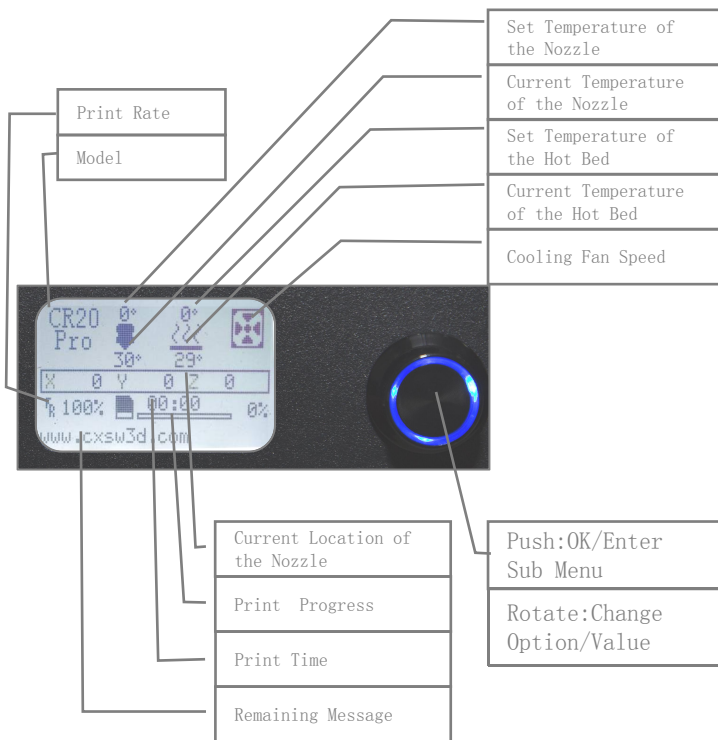

Screen Options

Menu	Sub Menu	Explanation
Info Screen	main	Return
Prepare	Disable Steppers	Moving X Y Z axis by your hands
	Auto Home	Return to the origin
	Preheat PLA	Nozzle : 185°C Bed: 45°C
	Preheat ABS	Nozzle : 240°C Bed: 70°C
	Cool down	Close and cool down the nozzle
	BLTouch Self-Test	
	Set home offsets	
	Move Axis	Moving X Y Z axis or Extruder by given value
Control	Temperature	Heat the nozzle and the bed or change fan speed by given value
	Filament	
	BLTouch	
	Restore Failsafe	Restore factory setting
No SD card/Print from SD		
Init. SD-Card/Change SD-Card		Select the printing model
printing		
Tune	Speed	Adjust percentage of printing speed
	Nozzle	Adjusting extrusion head temperature
	Bed	Adjusting hot bed temperature
	Fan speed	Adjust fan speed
	Flow	Adjust consumable flow percentage
Change Filament		Replace filament
Pause Printing		
Stop printing		

Loading Filament

Preheat

Method 1

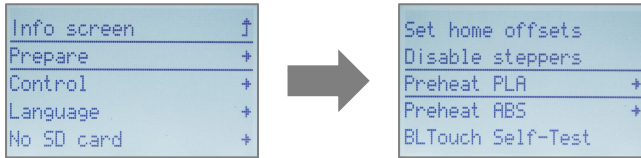

Method 2

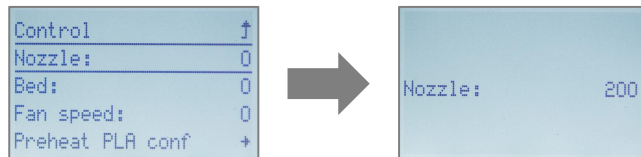
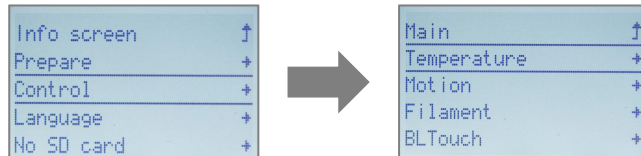

Feeding

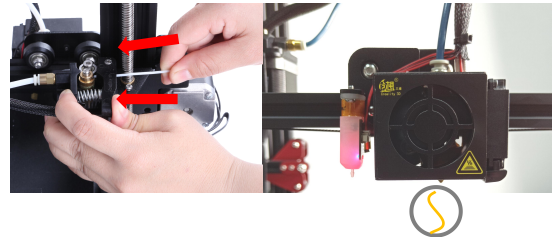

Press and hold the extruder lever then insert the 1.75mm filament through the small hole of the extruder. Continue feeding until you see filament come out the nozzle.

Tip: How to Replace the Filament?

- 1、Cutting filament near the Extruder and slowly feed new filament until they are fed into the new filament.
- 2、Preheating the nozzle and withdraw the filament quickly and feed the new filament.

Bed Leveling

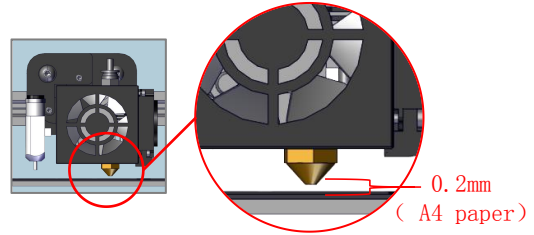
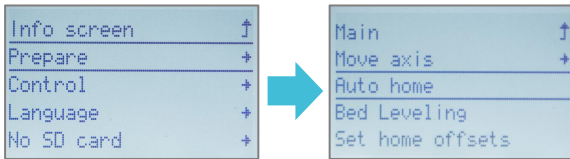

1. Prepare → Auto home, and wait to stop.

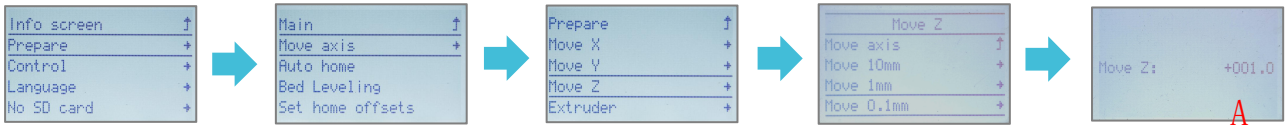

2. Prepare → Move axis → Move Z → Move 0.1mm → Rotate the knob until the distance between them is about 0.2mm (as a sheet of A4 paper), write down the value of A.

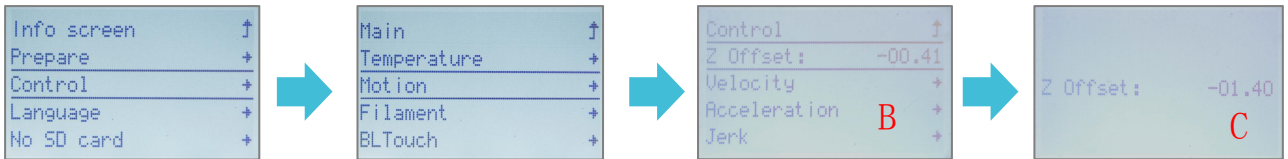

3. Control → Motion → Z Offset → write down the value of B, then rotate the knob until it comes out as: $C = B - A$.

Software Installation



Ultimaker
Cura-3.4.1-win64
4.exe



CR20Pro Set
For Cura
3.X.exe

1. Install the
Cura Slicing
Software.

2. Install the
Creality Set For
Cura with the same
file.

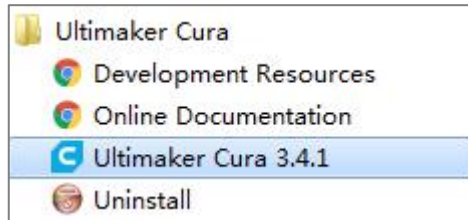

3. Start Cura from the Start
Menu.

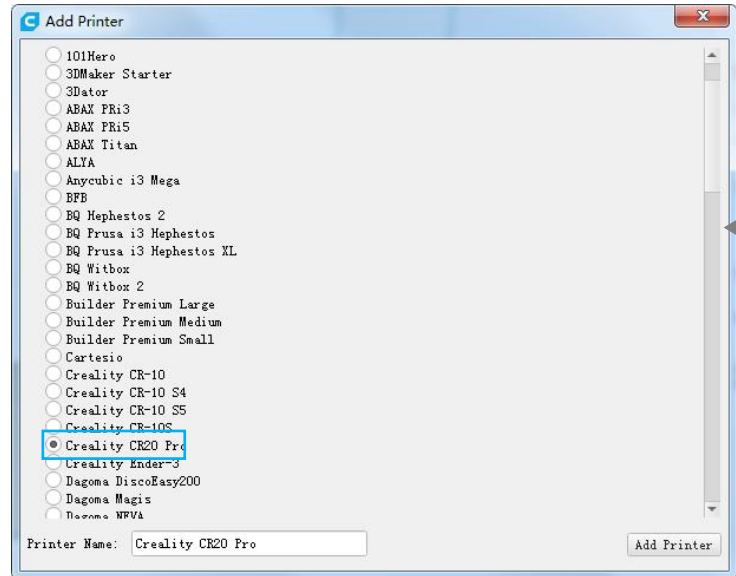

4. Select Creality CR20 Pro→Add Printer.

For the first Printing

1. Slice

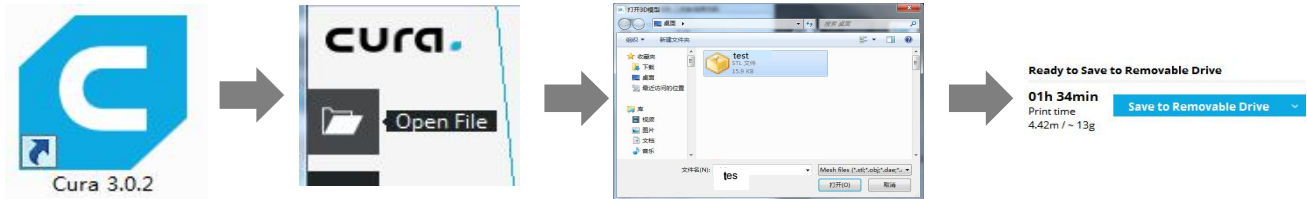

Open Cura → Open File → Select Model → Slice Model → Save to Removable Drive

2. Printing



Insert the TF card

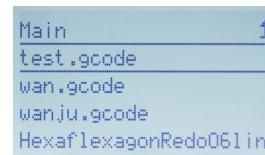
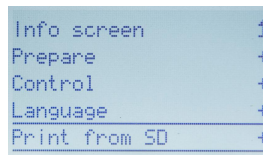

Select Print from SD → Select the file to print

Troubleshooting

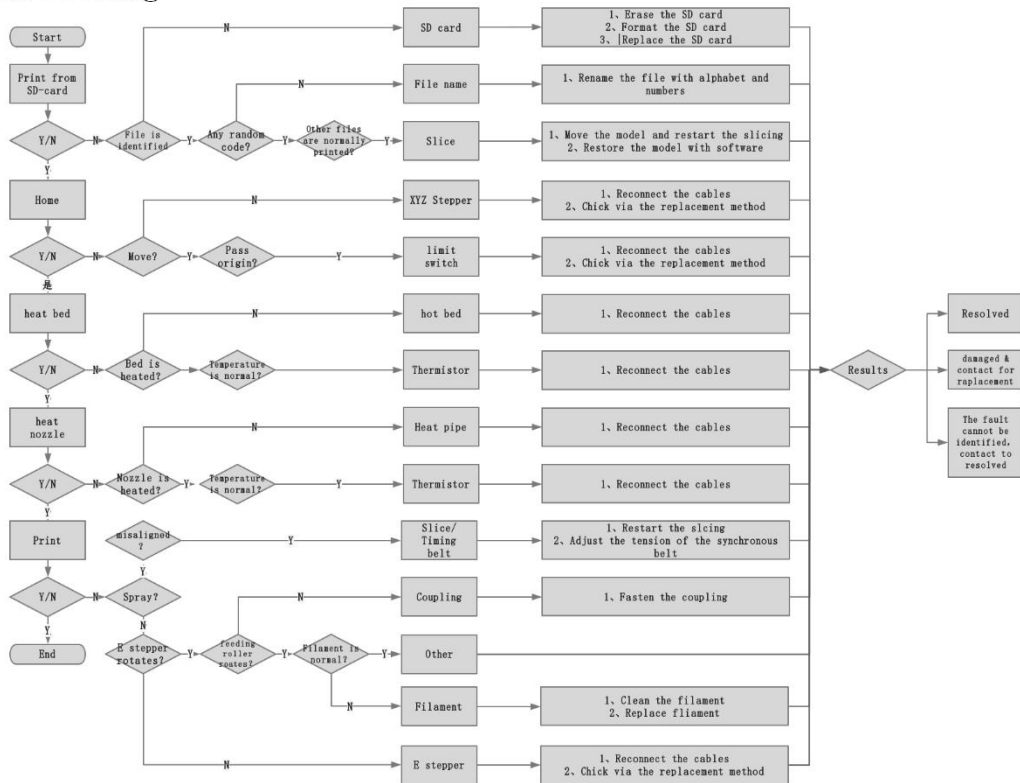

Circuit wiring

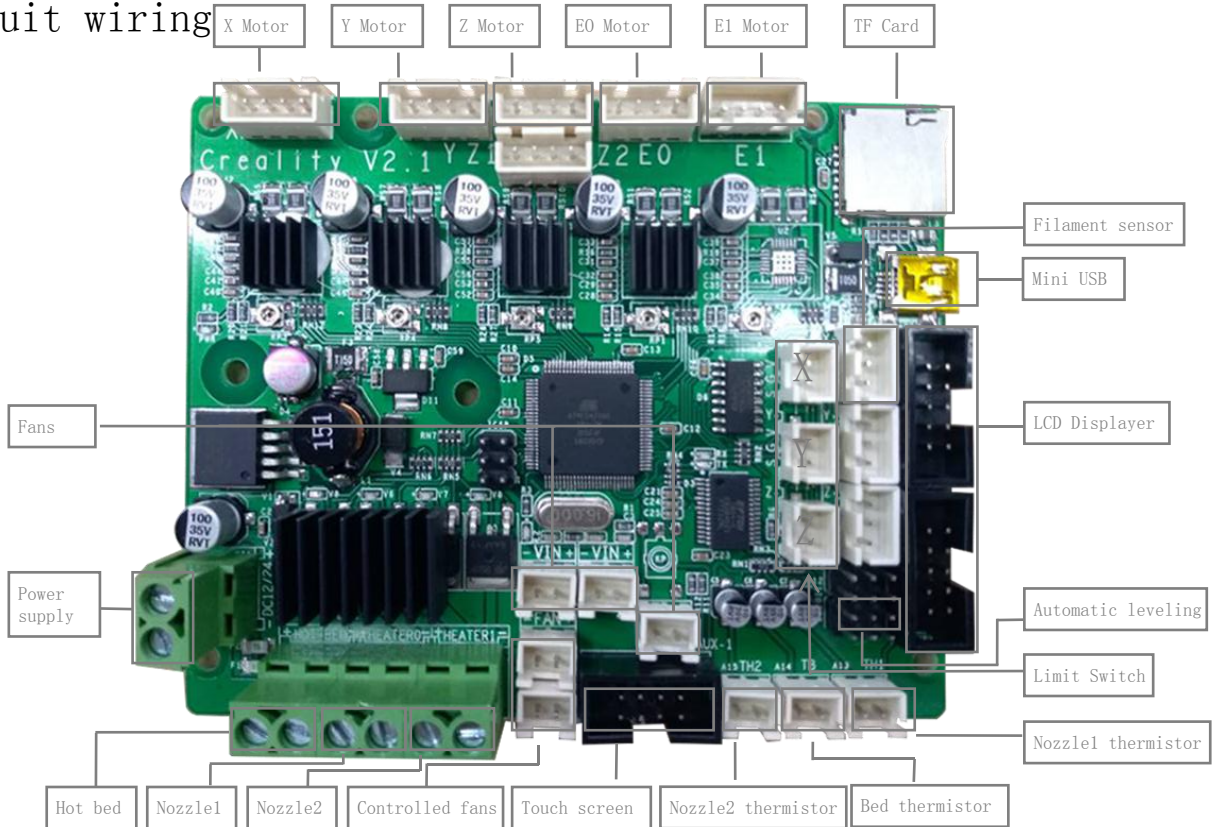

After- Sales Service

Service

1, The printer can be returned within seven days, 15 days replacement, one year warranty, lifetime maintenance.

Replacement requirement

1. The appearance of the product is intact, without damage, scratches, smudges, cracks, deformation, etc.;
2. Machine parts, tools and others are complete;
- 3, Provide a complete and valid purchase invoice and warranty, product number should be the same.

Warranty coverage

1. The following accessories are not included in the warranty coverage if they are not damaged by transportation: platform sticker; platform forming plate; acrylic cover; card reader and SD card; platform glass; USB cable; filament; rack and tools, etc.
- 2, Profile: Before we deliver the goods, we will do the machine test, so maybe there will be light scratch, or due to long-distance transportation, which scratch the profile a little bit. in the premise of not affecting the normal use, in principle, not within the scope of warranty;
- 3, Nozzle assembly (nozzle, heating block, throat pipe, heat sink, Teflon tube, etc.) warranty period is 3 months, if it is damage after the warranty expires, you need to purchase another one;
- 4, Motherboard, LCD display, power supply, hot bed, warranty period is 12 months, if there are quality problems, you can get free maintenance; over the warranty period, can be sent back to the original factory maintenance, the users need to bear the return shipping and maintenance costs;
5. Not included in warranty coverage:
 - (1) It is not possible to provide an effective after-sales service card or serial number;
 - (2) The whole machine and components exceed the warranty period;
 - (3) Equipment failure or damage caused by unauthorized modification of the equipment (private modification includes: 1. modification of the nozzle assembly; 2. modification of the machine structure; 3. use of third-party components; 4. use of third-party firmware procedures or change the original Factory firmware program, etc.);
 - (4) Equipment failure or damage due to incorrect installation and use;
 - (5) Equipment failure or damage caused by the use of the equipment in a working environment not specified by the product;
 - (6) Equipment failure or damage due improper use (beyond workload, etc.) or maintenance (moisture, etc.);
 - (7) Equipment failure or damage due to the use of other branded components or low quality consumables.

Description of warranty freight

- 1, Can be returned within 7 days, In case of quality problem of the machine, the freight is borne by the manufacturer; if it is a non-quality problem return, the user must bear the freight, and need to deduct the corresponding machine damage costs and consumables costs;
 - 2.7 days to 30 days, the freight shall be borne by the manufacturer if the goods need to be replaced or returned to the factory for maintenance due to quality problems; If the goods need to be replaced due to non-quality problems, the customer shall bear the freight. In principle, it is not allowed to exchange goods over 7 days without quality problems;
 - 3, Within 1 - 3 months need to return to the factory for maintenance, if in case of the quality problem, the freight is borne by the user and the manufacturer, and does not charge any maintenance costs;
 - 4, Within 3 - 12 months need to return to the factory for maintenance, the freight is borne by the user, If it is non-human damage, the spare parts and labor costs for maintenance shall not be charged.
- Exceeding the warranty period, the user will bear the freight and maintenance costs, and the manufacturer provides technical support.
- Special note: If you are a foreign user, we will take some special methods according to the actual situation to provide users with better after-sales service.

The final interpretation right belongs to Shenzhen Creality3D Technology Co., Ltd.!



Facebook QR code



Website QR code

SHENZHEN CREALITY 3D TECHNOLOGY CO., LTD.

12/F, Block 3, JinChengYuan, Huafan Road, Tongsheng Community, Dalang,
Longhua District, Shenzhen, China, 518109

Official Website : www.creality3d.cn

Tel: +86 755-2103 4006

E-mail: info@creality3d.cn cs@creality3d.cn